

**DIMENSIONS, WEIGHTS AND ELECTRICAL DATA**
**1Ph - 220-230V**

TYPE	HP	Lenght (mm)			Weight (Kg)			In max Amp	run μ F	starting μ F
		P.L.	M.L.	T.L.	PUMP	MOTOR	TOTAL			
AP6B3	3*	402	470	872	7,1	14,2	21,3	16,8	60	189-227

**3Ph - 380V**

TYPE	HP	Lenght (mm)			Weight (Kg)			In max Amp
		P.L.	M.L.	T.L.	PUMP	MOTOR	TOTAL	
AP6B3	3*	402	420	822	7,1	12	19,1	6,5
AP6B4	4*	440	550	990	7,7	18,5	26,2	9,3
AP6B6	5,5*	516	580	1096	9,1	20	29,1	11,4
AP6B8	7,5*	592	650	1242	10,4	22,4	32,8	14,5
AP6B12	10	744	600	1344	13	27	40	19,6
AP6B14	12,5	820	600	1420	14,3	45	59,3	25
AP6B17	15	934	700	1634	16,3	48	64,3	28,1
AP6B20	17,5	1048	700	1748	18,3	50	68,3	33
AP6B24SD	20	1375	760	2135	24,4	54	78,4	36,9
AP6B29SD	25	1565	830	2395	27,7	65	92,7	43,5

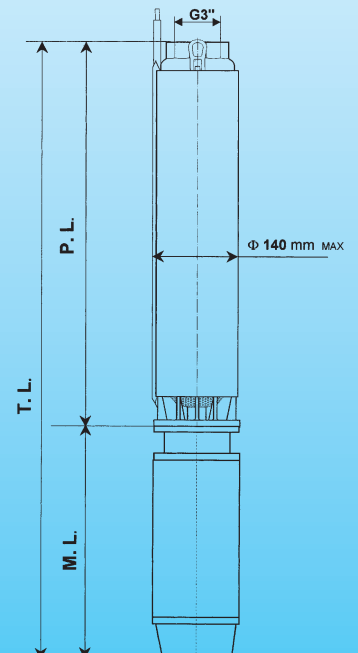

\* Motor 4"